



IGNITE THE POWER OF NATURE

Polycrystalline Module
--small size 90Watt

Model (SL90TU-18SP) Specifications



Electrical Data

Maximum Power(W)	90W
Optimum Power Voltage(Vmp)	18.32V
Optimum Operating Current(Imp)	4.91A
Open Circuit Voltage(Voc)	22.28V
Short Circuit Current(Isc)	5.26A
Cell Efficiency (%)	16.32%
Module Efficiency (%)	13.82%
Tolerance Wattage(e.g. +/-3%)	0~+3%
NOCT	47°C +/-2°C

Benefits

- ☐ High efficiency solar cells with high transmission and textured glass are delivering high efficiency for modules;
- ☐ Bypass diode minimizes the power drop caused by shade;
- ☐ Tempered glass, EVA resin, and weatherproof film, plus aluminum frame for extended outdoor use;
- ☐ Modules independently tested to ensure conformance with certification and regulatory standards;
- ☐ Manufacturing facility certified to ISO 9001 quality management system standards.

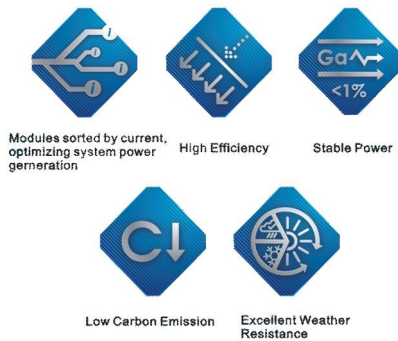

Applications

- ☐ On-grid residential roof-tops
- ☐ On-grid commercial/industrial roof-tops
- ☐ Solar power stations
- ☐ Other on-grid applications

Temperature Coefficients

Temperature Coefficients of Isc(%)°C	+0.04
Temperature Coefficients of Voc(%)°C	-0.38
Temperature Coefficients of Pm(%)°C	-0.47
Temperature Coefficients of Im(%)°C	+0.04
Temperature Coefficients of Vm(%)°C	-0.38





IGNITE THE POWER OF NATURE

Polycrystalline Module --small size 90Watt

Components & Mechanical

Solar Cell	125*125 Poly
Number of Cell(pcs)	4*9
Size of Module(mm)	1195*545*35
Front Glass Thikness(mm)	3.2
Surface Maximum Load Capacity	2400-5400Pa
Allowable Hail Load	23m/s ,7.53g
Weight Per Piece(KG)	10.0
Bypass Diode Rating(A)	10
Frame(Material Corners,etc.)	35#
Backing (Brand Type)	TPT
Temperature Range	-40°C to +85°C
FF (%)	70-76%
Standard Test Conditions	AM1.5 1000W/m ² 25°C

Warranty

Warranty	25 years limited power warranty
	10 years limited product warranty

Packing

Packing	Wooden Box
Pieces per container	30pcs/Pallets

Proiect Picture



Engineering Drawings

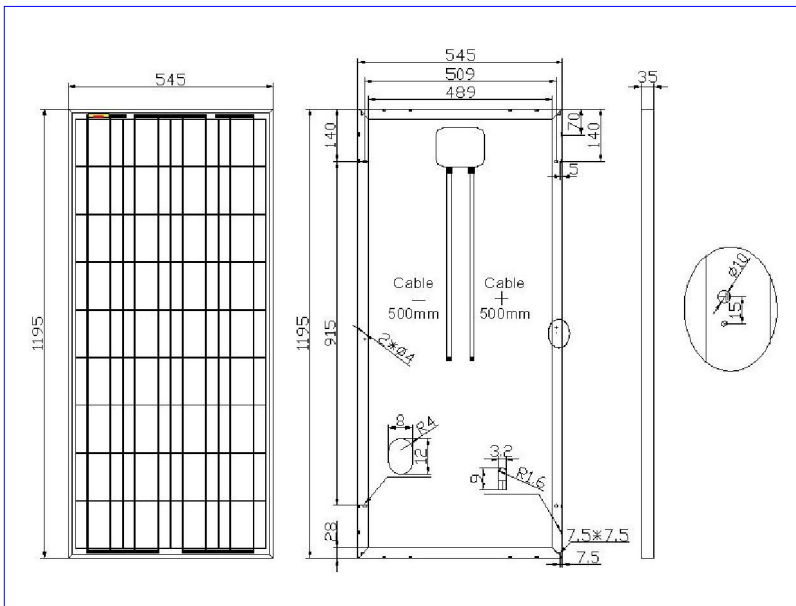

© 2013 Ningbo Qixin Solar Electrical Appliance Co., Ltd. All rights reserved.
Specifications included in this datasheet are subject to change without notice.



2

Ningbo Qixin Solar Electrical Appliance Co., Ltd

ADD: No. 37 Jingang Road, Binhai Industrial Park,
Xiangshan County, Ningbo, 315700, China

TEL: 0086 (0)574 25758821

FAX: 0086 (0)574 25758820

E-mail: info@nbqxsolar.com