

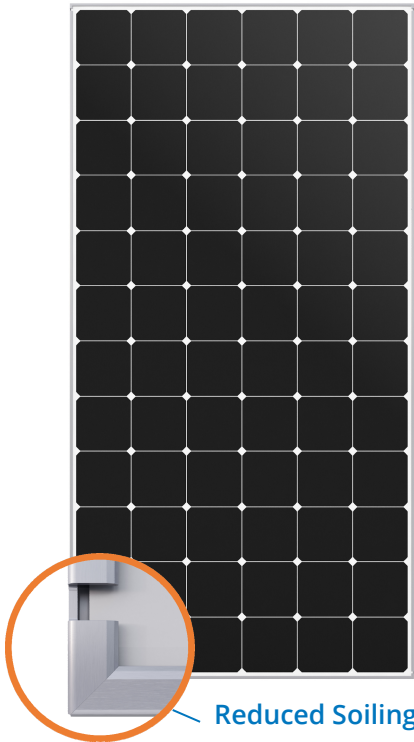

430–450 W Commercial A-Series Panels

SunPower® Maxeon® Technology

SunPower® Maxeon® cell-based panels maximize energy production and savings by combining industry-leading power, efficiency, and durability with the best power, product, and service warranty in the industry.^{1,2}



Reduced Soiling

NEW drainage notch improves performance



Highest Power Density Available

SunPower's new Maxeon® Gen 5 cell is 65% larger than prior generations, delivering the most powerful cell and highest efficiency panel in commercial solar. The result is more power per square meter than any commercially available solar.¹

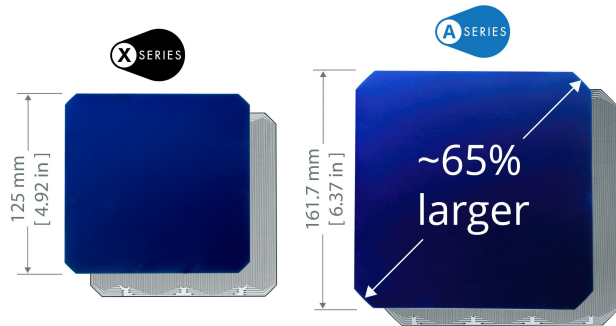

SUNPOWER MAXEON SOLAR CELL TECHNOLOGY

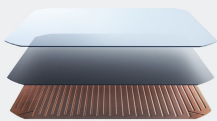

Fundamentally Different. And Better.

- Most efficient cell in commercial solar²
- Delivers unmatched reliability³
- Patented solid metal foundation prevents breakage and corrosion

As sustainable as the energy it produces.

- Achieved the #1 ranking on the Silicon Valley Toxics Coalition's Solar Scorecard for 3 years running
- SunPower modules can contribute to your business's LEED certification⁴



Maximum Lifetime Energy and Savings

Designed to deliver up to 60% more energy from the same space over the first 25 years in real-world conditions like partial shade and high temperatures.¹

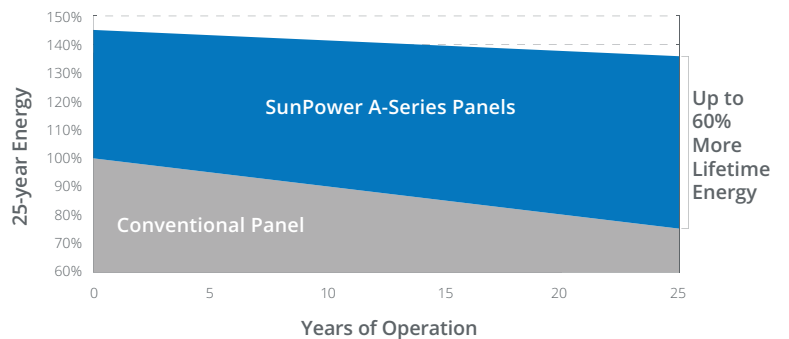

Best Reliability, Best Warranty

SunPower technology is proven to last and we stand behind our panels with the industry's best 25-year Combined Power, Product and Service Warranty.



430–450 W Commercial A-Series Panels

Electrical Data			
	SPR-A430-COM	SPR-A440-COM	SPR-A450-COM
Nominal Power (P _{nom}) ⁵	430 W	440 W	450 W
Power Tolerance	+5/0%	+5/0%	+5/0%
Panel Efficiency	21.2%	21.7%	22.2%
Rated Voltage (V _{mpp})	42.7 V	43.4 V	44.0 V
Rated Current (I _{mpp})	10.1 A	10.2 A	10.2 A
Open-Circuit Voltage (V _{oc})	51.2 V	51.6 V	51.9 V
Short-Circuit Current (I _{sc})	10.9 A	10.9 A	11.0 A
Max. System Voltage	1500 V UL		
Maximum Series Fuse	20 A		
Power Temp Coef.	-0.29% / ° C		
Voltage Temp Coef.	-136 mV / ° C		
Current Temp Coef.	5.7 mA / ° C		

Tests And Certifications	
Standard Tests	UL1703
Quality Management Certs	ISO 9001:2015, ISO 14001:2015
EHS Compliance	OHSAS 18001:2007, lead free, Recycle Scheme
Ammonia Test	IEC 62716 (Pending)
Desert Test	MIL-STD-810G (Pending)
Salt Spray Test	IEC 61701 (maximum severity) (Pending)
PID Test	1500 V: IEC 62804
Available Listings	UL, CEC

Operating Condition And Mechanical Data	
Temperature	-40° F to +185° F (-40° C to +85° C)
Impact Resistance	1 inch (25 mm) diameter hail at 52 mph (23 m/s)
Appearance	Class A
Solar Cells	72 Monocrystalline IBC cells
Tempered Glass	High-transmission tempered anti-reflective
Junction Box	IP-68, TE (PV4S)
Weight	47.7 lbs (21.6 kg)
Max. Load	Wind: 75 psf, 3500 Pa, 357 kg/m ² front & back Snow: 125 psf, 6000 Pa, 612 kg/m ² front
Frame	Class 2 silver anodized

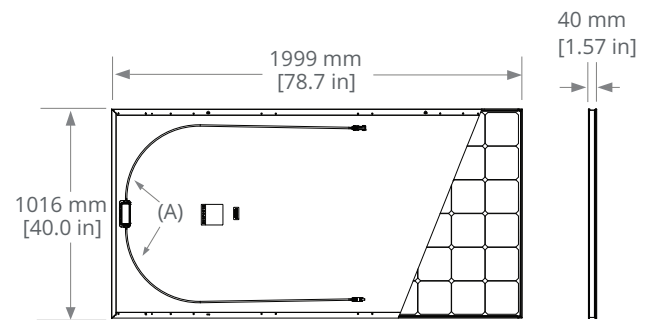

FRAME PROFILE

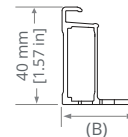

(A) Cable Length: 1320 mm +/-10 mm [52 in +/-0.4 in]

(B) Long Side: 32 mm [1.3 in]

Short Side: 24 mm [0.9 in]

Please read the safety and installation guide.

1 SunPower 450 W, 22.2% efficient, compared to a Conventional Panel on same-sized arrays (310 W, 16% efficient, approx. 2.0 m²), 4.9% more energy per watt (based on PVsyst pan files for avg US climate), 0.5%/yr slower degradation rate (Jordan, et. al. "Robust PV Degradation Methodology and Application." PVSC 2018).

2 Based on search of datasheet values from websites of top 20 manufacturers per IHS, as of January 2019.

3 #1 rank in "Fraunhofer PV Durability Initiative for Solar Modules: Part 3". PVTech Power Magazine, 2015. Campeau, Z. et al. "SunPower Module Degradation Rate," SunPower white paper, 2013.

4 A-Series panels additionally contribute to LEED Materials and Resources credit categories.

5 Standard Test Conditions (1000 W/m² irradiance, AM 1.5, 25° C). NREL calibration Standard: SOMS current, LACCS FF and Voltage.

See www.sunpower.com/company for more reference information.

For more details, see extended datasheet: www.sunpower.com/solar-resources. Specifications included in this datasheet are subject to change without notice.

©2019 SunPower Corporation. All rights reserved. SUNPOWER, the SUNPOWER logo, and MAXEON are registered trademarks of SunPower Corporation in the U.S. and other countries as well.